

## **SPECIFICATIONS FOR PLASTIC RAISED FLOOR PAVER PEDESTAL USED IN CLOSED AND OPEN AREAS FOR WOODEN AND STONE PAVING**

### **1. UNIT PRICE DESCRIPTION**

#### **1.1 PLASTIC RAISED FLOOR PAVER PEDESTAL FOR WOODEN DECK AND STONE SURFACING**

This is turnkey delivery price of m2 for the Plastic Raised Floor Paver Pedestals (Hereinafter referred to as PP) to be applied in sites specified in attached projects, in accordance with principle details and approved sample, manufactured as per TSE-K 99 Plastic Raised Floor Paver Pedestals Criteria and supplied by the manufacturer together with TSE-K Document or any equivalent international documents, and all kinds of material and losses, workmanship, tools, machinery, equipment rental and costs necessary for conducting laying works using PP and complementary products, correcting and/or disassembling and re-assembling of manufacturing, transportation, to reach final altitude and eliminate slope difference.

**MEASURE:** Assembled areas are calculated according to its project and approved attachments.

**BRAND:** SurPlot SERIES

### **2. GENERAL**

#### **2.1 OBJECTIVE**

This specification describes principles for "PP for Open Spaces Wooden and Stone Surfacing" and application details. The fact that application details or materials are approved by EMPLOYER/PROJECT MANAGEMENT does not relieve the MAIN CONTRACTOR of responsibilities related to used materials and conducted manufacturing. Manufacturing scope is summarized below and cannot be limited to them in special cases. The aim of this technical specification and appendix to the contract and details is to describe basic principles of the work to be done. To conduct manufactures in question, completely without any defects, but not limited to the below-mentioned aspects, all kinds of materials and workmanship is within the scope of these specifications and under the responsibility of the MAIN CONTRACTOR.

#### **2.2 DOCUMENTS RELATED TO THE PRODUCT**

PP should be manufactured as per TSE-K 99 PP criteria in effect and the manufacturer should have related TSE-K document or any equivalent international document.

EMPLOYER specific conditions describe general principles related to performing the work in question and in case of any contradictions between standards and specifications items, project author's approval shall be required.

#### **2.3 DELIVERIES**

2.3.1 In accordance with projects given in appendix to the contract, laying form, application details and usage area shall be given in manufacturing drawings to be prepared by the MAIN CONTRACTOR. Materials shall not be delivered to the construction site without approval of manufacturing drawings.

2.3.2 The catalogue showing compliance of products to characteristics connected to the specifications and certificates showing compliance to attributed standards shall be provided as per methods specified in the contract.

2.3.3 50-cm samples of products including finishing alternatives, plates and sub-construction of the system and other components of the system shall be submitted for approval before delivery to the site. Products submitted accordingly and approved can be used in the project.

2.3.4 A minimum of 4 m2 example application shall be implemented that displays all approaching and corner details in dimensions and locations approved by the Control and with selected materials. Once the application details are approved, then products can be used in the project.

2.3.5 Relationship between neighboring manufacturer, suggestions related to berthing details and assembly of manufacturer's products should be submitted for approval.

## 2.4 QUALITY ASSURANCE

2.4.1 All covering materials shall be procured from a company with at least 5 years of successful experience in terms of materials.

2.4.2 Manufacturing projects should be approved before starting application.

2.4.3 There should be a certificate showing that all materials to be used are procured from the responsible source.

2.4.4 Assembly in site should be conducted by experienced teams that are certified by the manufacturer or with at least 3 years of experience in similar projects.

## 2.5 ACCEPTANCE, STORAGE and TRANSPORTATION

2.5.1 All kinds of horizontal and vertical transportation of material to the site and application area are under the responsibility of MAIN CONTRACTOR. During transport and storage, materials shall not be damaged and their packing shall be protected against moisture. Discharge shall be done manually, if required, necessary machinery or suitable lifting gear for lifting and assembly processes shall be installed by the MAIN CONTRACTOR.

2.5.2 PP products should be stored in closed areas to avoid damage from moisture on carton packages in their original packages and they should be only stored 7 units on top at maximum.

2.5.3 During transportation of the material, attention shall be given to prevent prominent or permanent damage and unused materials should not be left in the site. In this respect, entire responsibility shall be on account of the MAIN CONTRACTOR.

## 2.6 WARRANTY

Warranty shall be evaluated for MAIN CONTRACTOR with the Contract and for manufacturer with general responsibilities determined by law.

2.6.1 Warranty period in completed productions;

\*5 years in materials

\*1 years in workmanship

Within the abovementioned warranty periods, repairs or renewal if required for defects that may arise as a result of material and/or applications errors; these operations shall be conducted by MAIN CONTRACTOR.

## 3. ELEMENTS

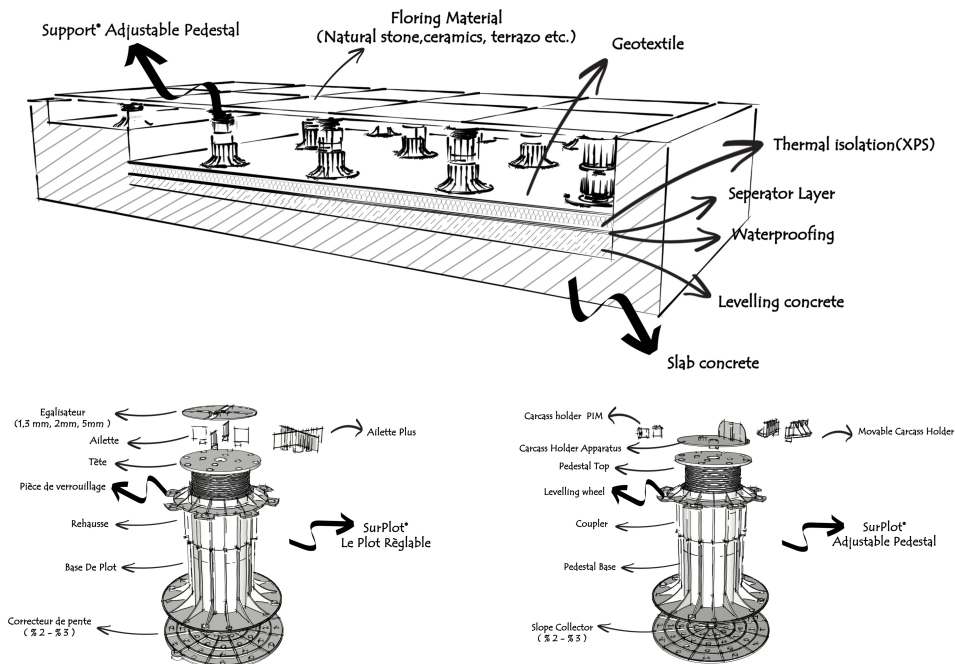

### 3.1 MAIN ELEMENTS

All materials shall be in specified qualities and dimensions in the project. In material selection, unless otherwise indicated, material types as per qualities and details shown in the following tables shall be used. All parts of the system that will be used should be recyclable and resistant to weather conditions, chemicals and corrosion. Bearing capacity for each pedestal should comply with TSE-K 99 Criteria (min. 900 kg). Pedestal system and byproducts should be polypropylene based and adjustable between 35mm and 600mm, stainless screws shall only be used in wooden deck connections.

#### 3.1.1 Top Unit

Diameter = 120 mm Surface=113cm<sup>2</sup>

Peak base including peak plate and cylinder body is a screwed system available for height adjustment, and it is connected to lower base or ascender by screwing. Along with rectangle sectioned coatings, to use with various different surfaces such as triangle, hexagonal ones; there should be holes to assemble positioning (joint) bars on peak base upper surface.

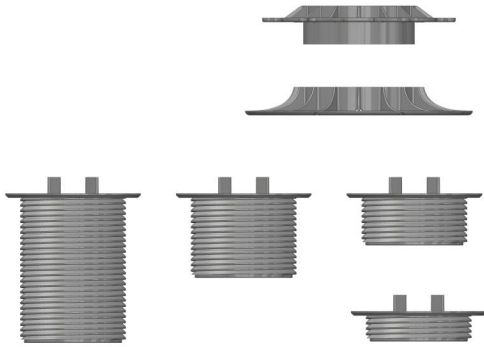

#### 3.1.2 Base Unit

Diameter =200 mm Surface=314 cm<sup>2</sup>

Base plate should be in a design to prevent damaging insulation layer on surfaces covered with insulation materials like PVC, EPDM, TPO etc. Base plate, if required, should be able to connect to the floor by means of holes through sticking or screwing. If the system is required to be raised, parts should be separated and raising apparatus should be installed. The base should have drainage holes allowing the liquid to be collected inside. To correct slopes on the floor, slope fixing wedges should be possible for installing between lower base and floor.



### 3.1.3 Coupler (Raising Apparatus)

Outer Diameter of the Cylinder = 102mm

The raising apparatus shall be used for the heights over 260 mm. The apparatus should consist of two cylinders interlocking with each other. There should be holes to allow drainage of rain water within the raising apparatus.



### 3.1.4 Positioning (joint) Strips

Thickness = 2- 3-4,7-6-8-10 mm

Shall be used in areas to be covered with stones. Joints mechanically should be able to turn 360 degrees by placing on slope raising head without using any other connection element.

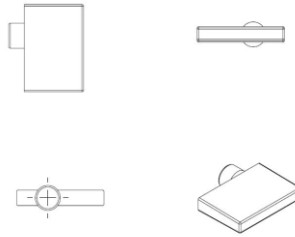

### 3.1.5 Carcass holders

#### 3.1.5.1 Fixed Carcass Holder

Thickness = 4 mm, Width/height = 20mm x 92.5mm

Shall be used in areas covered with wooden deck. Carcass holder shall be placed on the top of peak base and should have a design to ensure carcass stay on plates and if required, allow screwing of carcass on flooring pedestal.

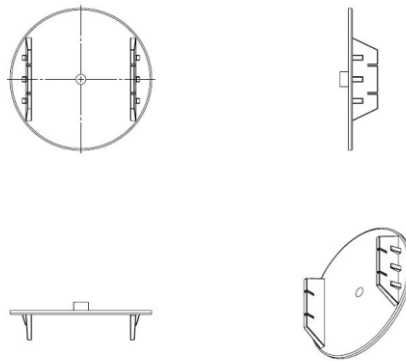

### 3.1.5.2 Movable Carcass Holder

Thickness = 4 mm, Width/length/height = 20mm x 80mm x 17mm

On the peak base where carcass is installed, two units of carcass holders working connected to juncture installed on two points located on axis allow placement of all types of carcasses in block center. For this, ball and socket joint arms are placed in holes on peak plate and fixed by screwing on screw holes on one of the arm, then the gap between other arm is eliminated by means of pressing and shifting and the center of related section of carcass is placed automatically on peak base.

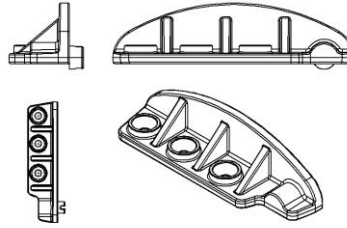

### 3.1.6 Slope Corrective Wedges

Diameter = 210mm, Area = 346 cm<sup>2</sup>, 2% -3%

Slope corrective wedges with circular section having various slope values should be in a quality to place under Base part and by centering to distribute weight evenly, they should be available for overlapping use in line with percent value of the slope and therefore, high valued slopes are also tolerable.

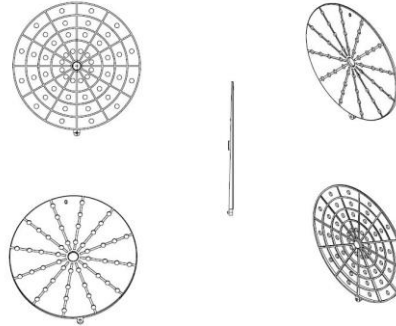

### 3.1.7 Calibration Adjustment Shims

Thickness = 1-2mm, Diameter = 105mm, Area = 86.55 cm<sup>2</sup>

Calibration adjustment seals with various circular cross-section thicknesses should be in a quality to eliminate calibration problems by installing of peak part and create an orthopedic surface.

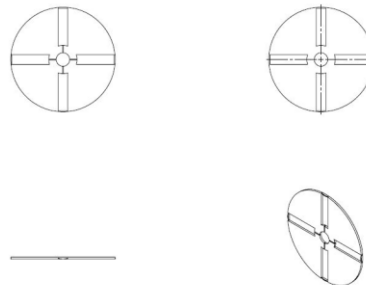

### 3.1.8 Adhesive

Where PPs are required to be glued on the surface, adhesives such as polyurethane, epoxy etc. could be used in tune with surface coating, in these cases, it should be noted that flooring pedestal includes polypropylene raw materials.

## 3.2 AUXILIARY ELEMENTS FOR APPLICATIONS

### 3.2.1 Auxiliary Applications for Wooden Applications

3.2.1.1 Stainless steel, galvanized or plastic (polypropylene) secret screwing (T) apparatus (for hidden screwing)

3.2.1.2 Stainless steel screws

3.2.1.3 Teak oil

3.2.1.4 Tile lifting apparatus (for Karodeck applications)

3.2.1.5 Other necessary hand tools to complete application

### 3.2.2 Auxiliary Elements for Stone Applications

3.2.2.1 Tile lifting apparatus

3.2.2.2 Other necessary hand tools to complete application

## 4. APPLICATION

### 4.1 OBSERVING AND PREPARATION

4.1.1 The CONTRACTOR shall examine current status of areas before work start and conduct necessary studies to prepare these areas for production.

4.1.2 In locations where timber cover is not suitable because of weather conditions, operations shall be suspended and after taking the work under protection, operations shall be stopped. However weather conditions do not affect the work in places to be covered with stones.

4.1.3 All insulation, waterproofing and other finished assembly areas shall not be damaged during installation, repair of damaged locations shall be provided immediately.

### 4.2 ASSEMBLY

#### 4.2.1 General Conditions

4.2.1.1 All productions should be conducted in pursuant of written descriptions by the Manufacturer and details of production drawings.

4.2.1.2 Materials should be brought to the construction site within their original packing which include specified label information.

4.2.1.3 All kinds of mechanical and electricity installations that will stay under the raised floor should be placed in accordance with foot layout. In case of delay in installation, installation shafts should be marked on the floor exactly where they will be applied and foot application should continue.

4.2.1.4 Locations where pedestals will be installed can be identified by means of rope one by one. 4.2.1.5 For effective usage of slope corrector, slope on the floor should be determined and pedestals should be lined on required level at final elevation.

4.2.1.6 Final slabbed elevation should be marked on surrounding walls and during montage duration PP height should be controlled as per elevation.

4.2.1.7 To overcome calibration problems that may occur in covering plate, 1mm and 2mm thickness calibration adjustment seals should be used.

4.2.1.8 In areas where paving will be conducted, positions (joint) strips should be used in a way to comply with requested dimensions and forms.

4.2.1.9 In areas of wooden deck flooring, carcass holder apparatus shall be used.

4.2.1.10 paving should be started by selecting the longest corner line and approved by employer or representative project designer.

4.2.1.11 Defective products should not be used, even if paving was completed, detected such type of products should be changed.

## ARMADA GROUPE

Yenibosna Merkez Mah. Prof. Dr. M.  
Nevzat Pisak Cad. No:4/2-11  
Bahçelievler/ İstanbul

Tel: +90 212 452 2060  
Fax: +90 212 452 2027  
www.armadagroupe.com  
www.surplot.com

4.2.1.12 after the installation, application area should be cleaned and should be protected as necessary.  
 4.2.1.13 Raised floors final elevation should be determined with the approval of the project architect; surface slope should be checked throughout the entire application with rope and jigs.

## 4.2.2 Application Details

### 4.2.2.1 Wood Applications

Area prepared for application shall be completed by marking all corner parapets. A modulation shall be determined in which edge trimmings will be minimize and which will provide visual satisfaction, and this shall be submitted to approval of the MAIN CONTRACTOR. You can start application from any corner. More than one slope wedge in accordance with % value of slope shall be used by stacking over and over, and therefore, high value slopes will be tolerated. Slope corrector wedges with circular cross-section and different slope degrees shall be placed under lower base and by centering.

PP amount shall be determined as per calculations compatible with construction & wood carcass and covering material dimensions; carcasses shall be placed on carcass holders located on pedestals and in case of using moving carcass holder, fixation by stainless screws on carcass holder shall be conducted. Final coating woods (decks) shall be fixed with stainless screws in the form of over screwing or hidden screwing on construction & wooden carcasses, ensuring to leave enough joint space.

In case of hidden screwing, suitable conduits for placing hidden screwing apparatus and for required joint space shall be provided. Polypropylene or stainless metal product "T" formed secret screwing apparatus shall fix decks on construction & wooden carcass.

PPs with variable adjustment heights through millimetric measuring shall be selected as per final elevation and construction and timber carcasses should be supported with PPs in a way to reach final elevation.

In rainy or too hot days, Teak oil application should not be conducted. Before application, the surface should be cleaned with a moist cloth against dust.

Application of teak oil shall be three-coated. A dry-clean cloth and flat brush are enough for application. Initially, the first layer of teak oil will be applied to the surface with a brush. After about a minute, a clean cloth will be used on the surface. Thus, the teak oil shall be spreaded on the surface evenly providing an equal absorption. During this process, it shall be noted that coats are not too thick (70gr/m<sup>2</sup>). Waiting duration between coats is at minimum 16 hours. Teak oil maintenance should be conducted once or twice a year based on conditions the wood is exposed to. General section and detail of wood application are shown below.

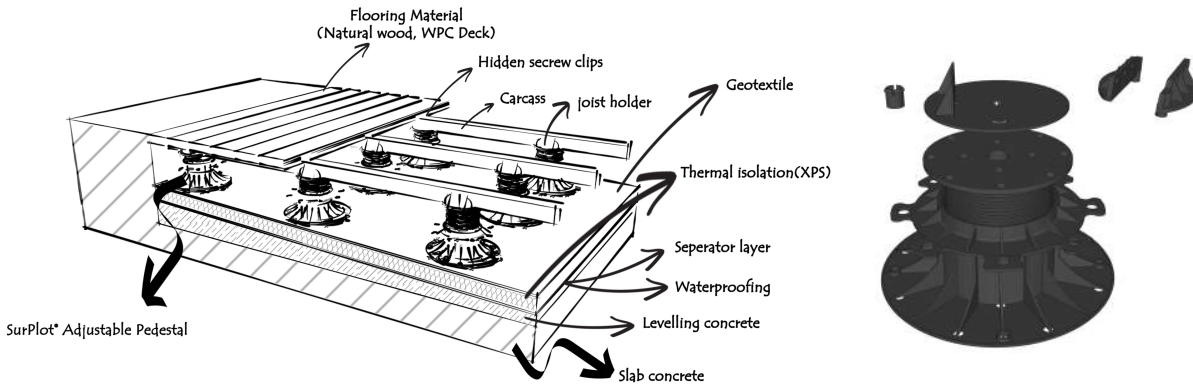

## 4.2.2.2 Stone Application

Area prepared for application shall be completed by marking all corner parapets. A modulation shall be determined in which corner cuttings will be minimized and which will provide visual satisfaction and this shall be submitted to approval of the MAIN CONTRACTOR. You can start application from any corner. More than one slope wedge in accordance with % value of slope shall be used by stacking over and over, and therefore, high value slopes will be tolerated. Slope corrector wedges with circular cross-section and different slope degrees shall be placed under lower base and by centering. In accordance with calculations as per coting material to be used, PPs shall be placed on middle center positing holes of 90 degrees by means of positioning (joint) laths. Therefore, each corner of facing stone shall be fixed on ¼ of PP.

12 pieces of corner positioning slots on top base provide to application adjustment up to 30 degrees angles on topbase; therefore, slot on the edges should be used at inclined cuts.

Calibration differences which occurred on covering materials shall be solved by using 1-2mm calibration adjustment seals; these seals could also be used in case of sound isolation . PPs with variable adjustment height through millimetric measures shall be selected compatible with final elevation, after paving of final elevation covering stone, PPs shall be adjusted by coupler (raising apparatus).

Heat-insulated terrace stone application details are shown below.

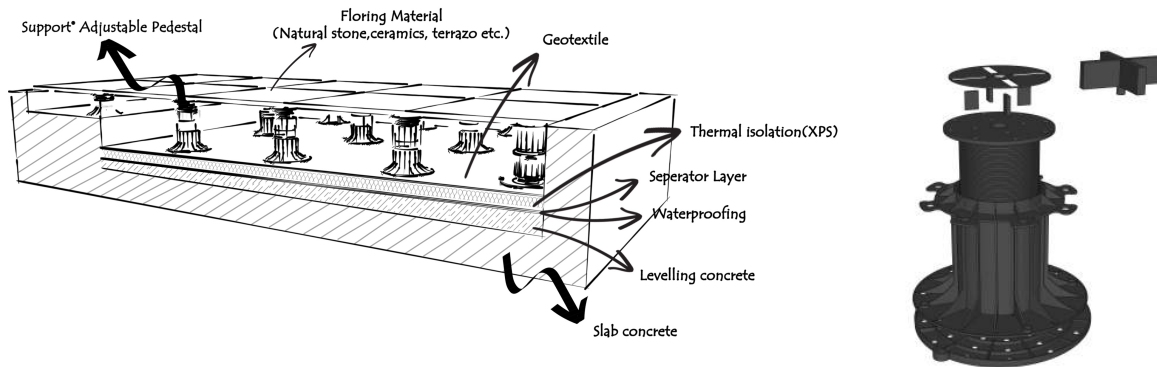

## 4.3 CLEARANCE

4.3.1 All left waste materials must be removed from the site according to the contract principles.

## 4.4 MAINTENANCE AND PROTECTION

4.4.1 All materials damaged during manufacturing and/or delivered as damaged shall be repaired or changed by the MAIN CONTRACTOR at specified locations and time zone. All repairs should be made the same as the original production quality.

4.4.2 All maintenance and protection should be carried out as specified by the manufacturer.